

FILTRATION GROUP

HEPA FILTER



- Standard and High Capacity (SC & HC)
- Proprietary automated computer test CIPAT (Computer Integrated Particulate Air Test)
- Controlled laminar flow
- Rugged construction
- Available in galvanized or stainless steel frame
- UL 900 Class I
- Also available for high temperature applications rated 400° F (HT4) or 500° F (HT5) (UL Class 2 only)



DESCRIPTION

The Aerostar HEPA (High Efficiency Particulate Air) filter is constructed with a 16 gauge galvanized or stainless steel frame with a continuous band of media pleated back and forth over corrugated aluminum separators. These filters contain a two-part polyurethane, which assures a positive seal of the media pack and frame. The interlocking frame design with sealant placed behind the top and bottom flange allows unobstructed airflow and ease of filter handling. Available for high temperature applications by using a different frame configuration with high temperature sealant and gasketing.

BENEFITS

The Aerostar HEPA filter's corrugated aluminum separators have proven to have 3 to 4 times more support to the media than other types of construction, thereby allowing use in higher humidity environments. These separators assure even pleat spacing for controlled laminar airflow.

The hemmed edges on the aluminum separators and square pleat design reduce possible pleat damage. HEPA filters are UL 900 Class I to meet strict fire codes. The HEPA HT filters are UL Class 2. In addition, filters, 99.97% DOP and higher, are tested on our CIPAT (Computer Integrated Particulate -Air Test) duct to assure compliance with overall efficiency specifications. The filters are tested with PAO (poly-alpha-olefin), approved by the US Army and Surgeon General as suitable replacement for DOP.

APPLICATIONS

The Aerostar HEPA filters remove a broad range of airborne contaminants, including fine dust, smoke, soot, pollen and radioactive particles. HEPA filters are used in final filter applications including hospitals, electronics, nuclear, pharmaceuticals, laboratories, aerospace, food processing and optics. They can also be used as pre-filters in cleanroom environments and other critical applications for final HEPA/ULPA/SULPA filters.

Distributed by:



FLORENCE FILTER CORPORATION

"Over 35 Years of Filter Excellence"

www.florencefilter.com

530 W. Manville • Compton • California 90220
(310) 637-1137 • FAX (310) 631-4323 • (800) 776-2021

7-03
P279

FILTRATION GROUP

HEPA FILTER

DIMENSIONS AND PERFORMANCE DATA

99.99% EFFICIENCY (MPPS 0.2 - 0.3 MICRONS SCANNED)

PART NUMBER†	ACTUAL FILTER DIMENSIONS (H x W x D)	RATED AIR FLOW (cfm)	PRESSURE DROP (CLEAN FILTER) ("w.g.)
--------------	--------------------------------------	----------------------	--------------------------------------

SC (STANDARD CAPACITY)-SCANNED

11392	12 x 12 x 11 ½	250	1.0
11399	24 x 12 x 11 ½	535	1.0
11402	24 x 24 x 11 ½	1150	1.0

HC (HIGH CAPACITY)-SCANNED††

54353	12 x 12 x 11 ½	435	1.45
54354	24 x 12 x 11 ½	930	1.45
51347	24 x 24 x 11 ½	2000	1.45

99.97% EFFICIENCY (MPPS 0.2 - 0.3 MICRONS SCANNED)

PART NUMBER†	ACTUAL FILTER DIMENSIONS (H x W x D)	RATED AIR FLOW (cfm)	PRESSURE DROP (CLEAN FILTER) ("w.g.)
--------------	--------------------------------------	----------------------	--------------------------------------

SC (STANDARD CAPACITY)-SCANNED

11410	12 x 12 x 11 ½	250	1.0
11411	24 x 12 x 11 ½	535	1.0
11420	24 x 24 x 11 ½	1150	1.0

HC (HIGH CAPACITY)-SCANNED††

54355	12 x 12 x 11 ½	435	1.45
51675	24 x 12 x 11 ½	930	1.45
50584	24 x 24 x 11 ½	2000	1.45

95% EFFICIENCY (MPPS 0.2 - 0.3 MICRONS SCANNED)

PART NUMBER†	ACTUAL FILTER DIMENSIONS (H x W x D)	RATED AIR FLOW (cfm)	PRESSURE DROP (CLEAN FILTER) ("w.g.)
--------------	--------------------------------------	----------------------	--------------------------------------

SC (STANDARD CAPACITY)-SCANNED

11424	12 x 12 x 11 ½	435	1.0
11425	24 x 12 x 11 ½	930	1.0
11429	24 x 24 x 11 ½	2000	1.0

CIPAT Tests performed on 99.97% and higher efficiencies.

† Contact Customer Service for additional sizes and information.

†† Airflow for high temperature filters at high capacity is reduced to 325, 700 and 1500 cfm at 1".

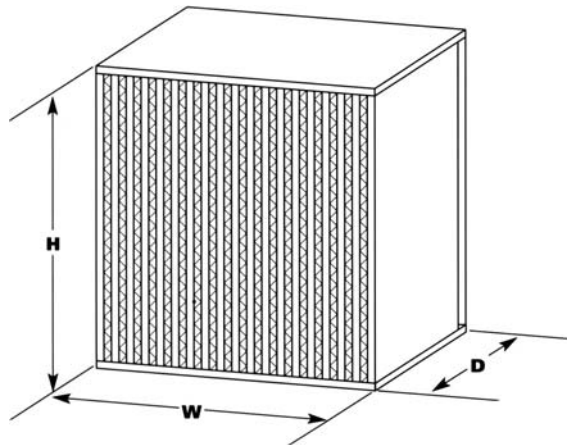

Distributed by:



FLORENCE FILTER CORPORATION

"Over 35 Years of Filter Excellence"

www.florencefilter.com

530 W. Manville • Compton • California 90220
(310) 637-1137 • FAX (310) 631-4323 • (800) 776-2021

APPLICATION PARAMETERS

Maximum Constant Temperature:

212° F (100° C)

*Optional models available for 400° F and 500° F

Recommended Final Pressure Drop:

2.0" w.g.

Flammability:

UL 900 Class 1

UL 900 Class 2 *High temperature

Relative Humidity:

100%

MATERIALS

Frames:

16 ga galvanized steel

*304 Stainless Steel-optional

Media:

Wet laid microglass paper

Separators:

Corrugated aluminum with hemmed edges both sides

Sealant:

Polyurethane

*Silicone for the High Temperature

Gasketing:

HD-urethane ¼" x ⅝" wide, dove-tailed corner connections, downstream

*Silicone sponge for the High Temperature

*High Temperature Filter - for information and part numbers, consult customer service.