

FILTRATION GROUP

RESIDENTIAL REPLACEMENT FILTERS

- Universal replacements for leading brands
- Quality construction and efficient media
- No retrofit needed to install
- Simple upgrade for home filtration systems
- Cabinet easily adapts to most furnaces



Replacement filters for brand name high efficiency media air cleaners used in forced air HVAC systems. Filter performance meets or exceeds the specifications established by the original manufacturer.

Residential replacement products include universal replacements for many leading brands, such as:

- Honeywell
- Spaceguard
- General
- Trion Air Bear

Filters are designed to match the original manufacturers dimensions and therefore no cumbersome retrofit steps are needed to install.

The Air Cleaner Cabinet is designed for residential and light commercial forced-air heating and/or cooling systems. Units handle most central forced air furnace installations.

High efficiency filtration removes up to 98% of the dust, dirt, smoke, pollen, bacteria, and other contaminants. Removes up to 80% of particles in the air down to 1.0 microns in size, large dust holding capacity has 100 square feet of filter media. This filtering system's low pressure drop makes it ideal even for heat pump applications.

Filtration Group's air cleaner cabinet is easy to install because of built in flanges into furnaces. For duct size 20" x 22 1/2".

- No electrical connections necessary
- No electricity consumed
- Does not produce ozone
- Quick, easy, clean maintenance

Slide out dirty cartridge and replace with new one. Filter media cartridge (included) is completely factory assembled.

Distributed by:



FLORENCE FILTER CORPORATION

"Over 35 Years of Filter Excellence"

www.florencefilter.com

530 W. Manville ♦ Compton ♦ California 90220
(310) 637-1137 ♦ FAX (310) 631-4323 ♦ Out Of State (800) 776-2021

6/16/05
P311

FILTRATION GROUP

Residential Replacement Filters

Replacement Filter For Residential Air Cleaners

These filters are replacements to those supplied by the original manufacturer. Requires use of original manufacturer's spacers and dividers. Media filter is wet layered micro fiberglass paper. UL Classified as to flammability only; Class 2.



Replaces Manufacturer	Manufacturer's Model	Manufacturing Number	Shipping Weight
General	AC-1	10661	3.0
Honeywell	F66A	10660	3.0
Spaceguard	2200, 2250	10659	3.0

Air Bear Replacement Filters

Replaces filter cartridges used in the Trion Air Bear type air cleaner. "Little Bear" size also available. Equals or exceeds performance of the original filter. Media is moisture resistant, 100% synthetic. UL Classified as to flammability only; Class 2.



Model	Size W x H x D	Manufacturing Number	Shipping Weight
Air Bear	24 1/8" x 19 5/8" x 4 3/4"	12428	3.0
Little Bear	15 5/8" x 24 1/8" x 3"	22942	2.0

Air Cleaner Cabinet & Replacement Filters

Filtration Group Air Cleaner Cabinet	Part Number	Dimensions H x D x W	Approximate Weight (lbs.)
Cabinet	13158*	21 x 11 x 23 1/2	25.0
Replacement Filter Only	10658	Filter Pack of 4	17.0

* Includes filters

RAC Performance Data			
Air Flow	1200	1600	2200
Little Bear	.16	.23	.31

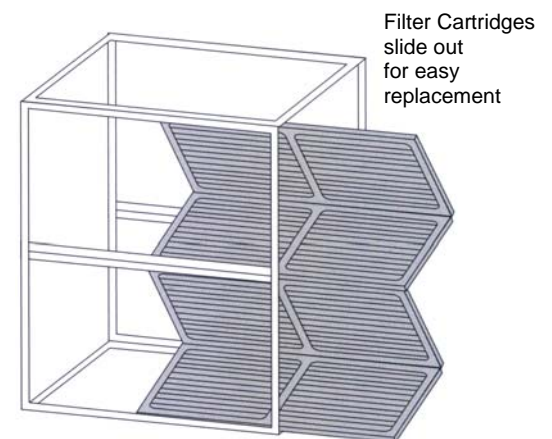

Distributed by:



FLORENCE FILTER CORPORATION

"Over 35 Years of Filter Excellence"

www.florencefilter.com

530 W. Manville ♦ Compton ♦ California 90220
 (310) 637-1137 ♦ FAX (310) 631-4323 ♦ Out Of State (800) 776-2021

6/16/05
 P311